

TO DIN 582

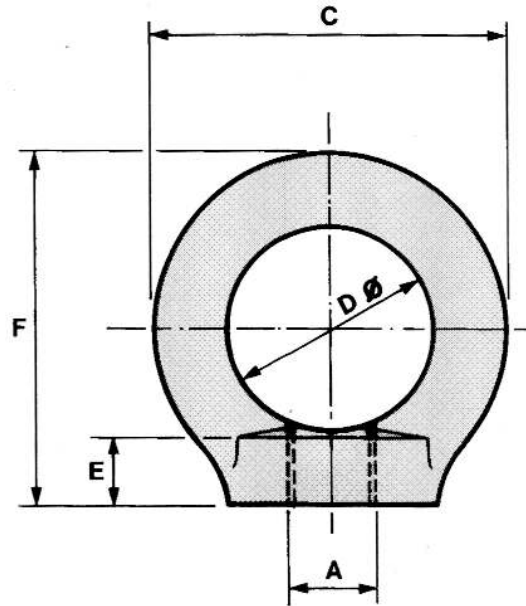
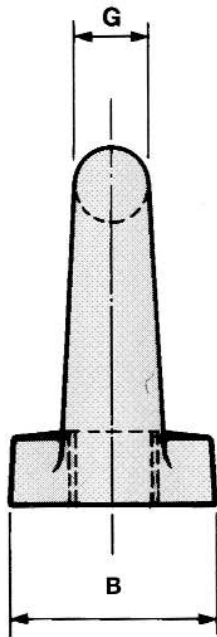

BFE  
25

A	B	C	D	E	F	G	SWL	Weight Each
mm	mm	mm	mm	mm	mm	mm	kgs	kgs
M6	20	36	20	8.5	36	8	70	0.05
M8	20	36	20	8.5	36	8	140	0.05
M10	25	45	25	10	45	10	230	0.09
M12	30	54	30	11	53	12	340	0.15
M14	35	63	35	13	62	14	490	0.24
M16	35	63	35	13	62	14	700	0.24
M20	40	72	40	16	71	16	1200	0.36
M22	45	81	45	18	81	18	1500	0.58
M24	50	90	50	20	90	20	1800	0.72
M27	50	90	50	20	90	20	2500	0.72
M30	65	108	60	25	109	24	3600	1.32
M33	65	108	60	25	109	24	4300	1.32
M36	75	126	70	30	128	28	5100	2.08
M39	75	126	70	30	128	28	6100	2.08
M42	85	144	80	35	147	32	7000	3.11
M45	85	144	80	35	147	32	8000	3.04
M48	100	166	90	40	168	38	8600	5.02
M52	100	166	90	40	168	38	9900	5.02
M56	110	184	100	45	187	42	11500	6.69
M64	120	206	110	50	208	48	16000	9.30

© Brooks Forgings Ltd 2008

### SPECIFICATIONS AVAILABLE

#### MATERIAL

CARBON STEELS  
STAINLESS STEELS  
ALLOY STEELS  
B7

SWL IS SHOWN FOR VERTICAL LIFT  
ITEMS SUPPLIED UNTESTED UNLESS  
REQUESTED

#### FINISH

SELF COLOUR  
GALVANISED  
ELECTROPLATED  
CHEMICAL BLACK  
PTFE COATING