

Dynamo Eyebolts - Commercial Pattern

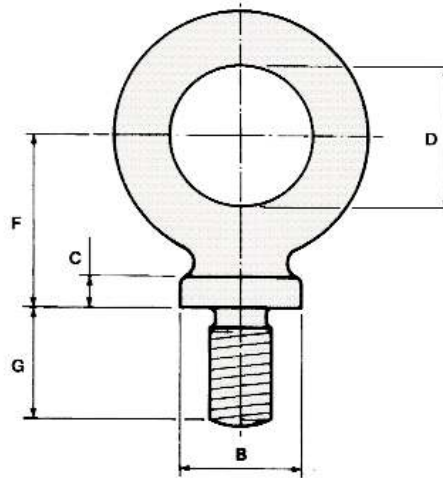
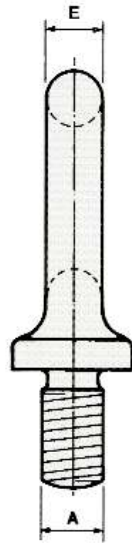

BFE
20

A	B	C	D	E	F	G	G	SWL	Weight Each	
Metric Imperial	DIA		DIA	DIA		STD Shank	Long Shank	Vertical	STD	LONG
inches	mm	mm	mm	mm	mm	mm	mm	kg/CWT	kg	kg
M6	19	6	22	10	27	19	101	60	0.08	0.10
1/4	3/4	1/4	7/8	3/8	1. 1/16	3/4	4	2	0.08	0.10
M8	19	6	22	10	27	19	101	95	0.08	0.10
5/16	3/4	1/4	7/8	3/8	1. 1/16	3/4	4	3	0.08	0.10
M10	19	6	22	10	27	19	101	160	0.08	0.10
3/8	3/4	1/4	7/8	3/8	1.1/16	3/4	4	5	0.08	0.10
M12	25	8	28	11	35	26	101	320	0.14	0.30
1/2	1	5/16	1. 1/8	7/16	1. 3/8	1	4	10	0.14	0.30
M16	28	10	32	13	41	28	115	630	0.24	0.45
5/8	1. 1/8	3/8	1. 1/4	1/2	1. 5/8	1. 1/8	4. 1/2	16	0.24	0.45
M20	36	13	40	17	54	32	127	1250	0.40	0.70
3/4	1. 3/8	1/2	1. 5/8	11/16	2. 1/8	1. 1/4	5	24	0.40	0.70
M22	38	13	44	17	57	41	127	1600	0.62	1.00
7/8	1. 1/2	1/2	1. 3/4	11/16	2. 1/4	1. 5/8	5	32	0.62	1.00
M24	41	13	51	21	64	45	127	2000	0.80	1.10
1	1. 5/8	1/2	2	13/16	2. 1/2	1. 3/4	5	44	0.80	1.10
M27	54	16	60	26	73	51	152	2500	1.76	2.20
1. 1/8	2. 1/8	5/8	2. 3/8	1	2. 7/8	2	6	56	1.76	2.20
M30	54	16	60	26	73	51	152	3200	1.70	2.20
1. 1/4	2. 1/8	5/8	2. 3/8	1	2. 7/8	2	6	70	1.70	2.20
M33	57	18	76	28	89	57	152	4000	2.60	3.20
1. 3/8	2. 1/4	11/16	3	1. 1/8	3. 1/2	2. 1/4	6	85	2.60	3.20
M36	57	18	76	28	89	57	152	5000	2.65	3.50
1. 1/2	2. 1/4	11/16	3	1. 1/8	3. 1/2	2. 1/4	6	100	2.65	3.50

© Brooks Forgings Ltd 2008

SPECIFICATIONS AVAILABLE

MATERIAL

BS970 080A27 (EN5A)

STAINLESS STEELS

ALLOY STEELS

B7

EYEBOLTS ARE SUITABLE FOR VERTICAL LIFTS ONLY

FINISH

- SELF COLOUR
- GALVANISED
- ELECTROPLATED
- CHEMICAL BLACK
- PTFE COATING