

Eye Nuts

**BFE
24**

A		B	C	D	E	F	H	SWL	Weight Each
mm	inches	mm	mm	mm	mm	mm	mm	kgs	kgs
M6	1/4	25	9	22	14	47	16	60	0.1
M8	5/16	25	9	22	14	47	16	95	0.1
M10	3/8	25	9	22	14	47	16	160	0.1
M12	1/2	44	13	29	22	78	23	320	0.3
M16	5/8	44	13	29	22	78	23	630	0.3
M18	---	47	16	39	26	84	31	1000	0.4
M20	3/4	47	16	39	26	84	31	1250	0.4
M22	7/8	47	16	39	26	84	31	1600	0.4
M24	1	52	21	44	38	105	36	2000	0.8

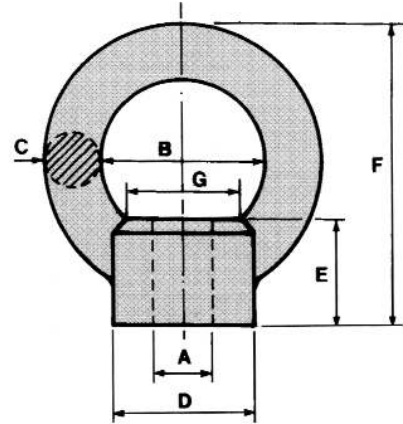

© Brooks Forgings Ltd 2008

SPECIFICATIONS AVAILABLE

MATERIAL
CARBON STEELS
STAINLESS STEELS
ALLOY STEELS
B7

S.W.L. SHOWN IS FOR VERTICAL LIFT ONLY
ITEMS SUPPLIED UNTESTED UNLESS REQUESTED

FINISH
SELF COLOUR
GALVANISED
SHERADIZED
ELECTROPLATED
CHEMICAL BLACK

tel. 01384 566772 fax. 01384 637380 web. www.brooksforgings.co.uk